



HEARNES
WHERE SERVICE COUNTS

**Wimborne
Dorset, BH21 2BL**

Wimborne, Dorset, BH21 2BL

FREEHOLD GUIDE PRICE: £640,000

A beautifully presented and deceptively spacious three bedroom detached bungalow offering a superb blend of comfort and modern living. The property features two generous size reception rooms and a modern fitted kitchen with a separate utility room. The accommodation also includes a large family bathroom and a master bedroom with an en suite shower room.

Externally, the property benefits from ample off-road parking with an oversized detached garage and an impressive, large rear garden, perfect for outdoor relaxation or entertaining.

- Spacious entrance hallway with built in cloak cupboard and double size airing cupboard, housing the hot water tank. Access to loft space which is partly boarded with loft ladder and light
- Double doors to good size sitting room with feature brick fireplace with oak beam mantel and coal effect gas fire. Square arch to dining room and patio doors leading onto patio and sunny rear garden
- Large dining room with double glazed sliding door leading to the raised patio
- Superb fully fitted 'Wren' kitchen with range of base and eye level units and drawers with complementary quartz worktops with quartz upstands, inset Neff induction 5 ring hob with two Neff 'slide and hide' ovens, integrated Miele fridge freezer and wine rack with quality flooring
- Separate utility room with space for washing machine, tumble dryer, fridge freezer, fitted cupboards with worktop and wall mounted Worcester gas boiler door to side and garden
- Three generous size bedrooms
- Main bedroom with built in wardrobes and bay window, with door to luxury en suite shower room
- Bedroom two with matching bay window and bedroom three currently used as an office/study
- Family bathroom with four-piece suite with Duravit bath and separate shower cubicle
- Double glazing and gas heating with serviced intruder alarm
- Electric sun awning blind to lounge and sun awning blind to dining room

Outside: to the front of the property there is a tarmac driveway giving off road parking and leading to over sized garage with electric up and over door with brick paviour driveway, then gives further off-road parking with attractive flower and shrub borders. Access can be gained down both sides of the property leading to the rear garden where a good size patio can be found, the garden then being laid to lawn with an abundance of mature trees, plants and attractive flower beds being enclosed by panel fencing.

COUNCIL TAX BAND: E

EPC RATING: D

AGENTS NOTES: The heating system, mains and appliances have not been tested by Hearn's Estate Agents. Any areas, measurements or distances are approximate. The text, photographs and plans are for guidance only and are not necessarily comprehensive. Whilst reasonable endeavours have been made to ensure that the information in our sales particulars are as accurate as possible, this information has been provided for us by the seller and is not guaranteed. Any intending buyer should not rely on the information we have supplied and should satisfy themselves by inspection, searches, enquiries and survey as to the correctness of each statement before making a financial or legal commitment. We have not checked the legal documentation to verify the legal status, including the leased term and ground rent and escalation of ground rent of the property (where applicable). A buyer must not rely upon the information provided until it has been verified by their own solicitors.





Ground Floor

Approx. 129.7 sq. metres (1396.6 sq. feet)

Garage

Approx. 22.8 sq. metres (245.4 sq. feet)

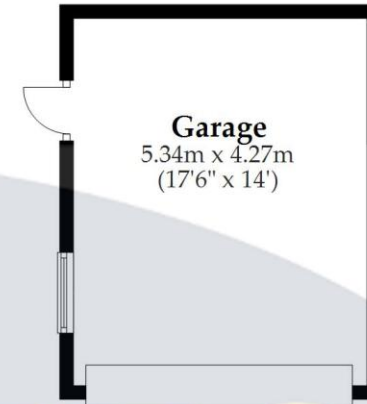
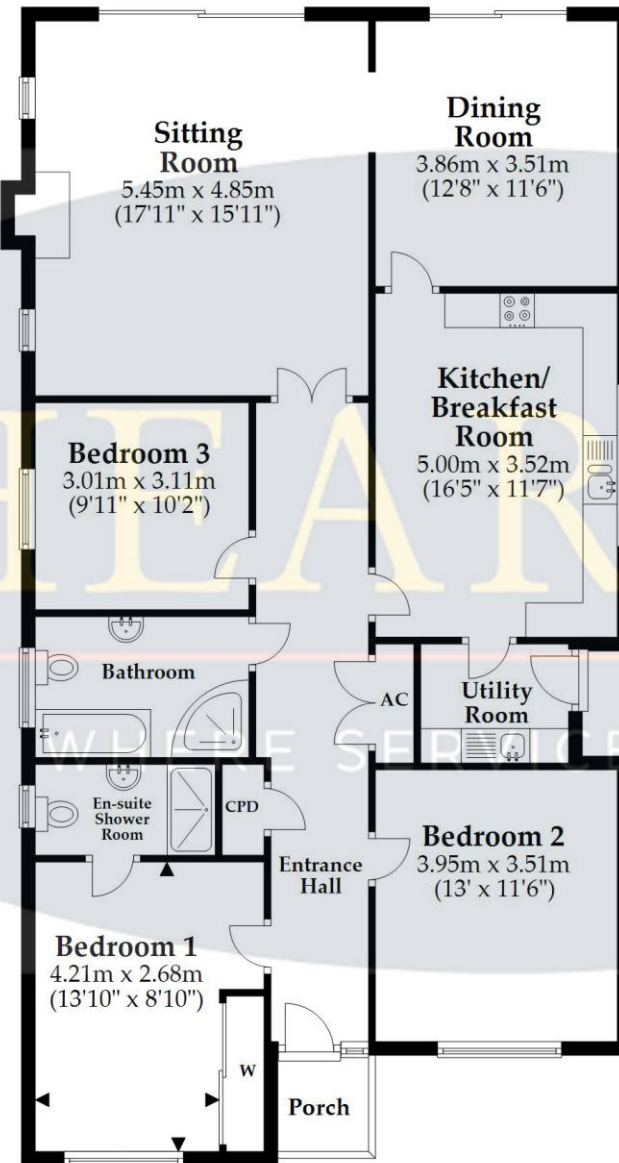

Total area: approx. 152.5 sq. metres (1642.0 sq. feet)

This plan is not to scale and is for general guidance only. LJT Surveying Ltd Ringwood







www.hearnes.com

6 Cook Row, Wimborne, Dorset BH21 1LB

Tel: 01202 842922 Email: Wimborne@hearnes.com

OFFICES ALSO AT: BOURNEMOUTH, FERNDOWN, POOLE & RINGWOOD